

DN40 – DN600 resp. 1 1/2" – 24"

Suited for safe non-return flow control of corrosive fluidic media to be handled in process piping systems.

Modular Design

SSC Swing Check Valves Series are available as wafer-style types, for horizontal or vertical installation between flanges acc. to DIN PN10/16 or ANSI 150lbs.

The sturdy design bodies are made of cast steel 1.0619 (WCB), coating RAL 5005 signal-blue or stainless steel casting 1.4408 (CF-8M), with resistant linings such as PFA or PFA-AS (anti-static).



SSC

Body 1.0619 (WCB)/PFA

Main Features

- DIN/ANSI combined, optimized design
- 2- or 3-piece bodies made of cast steel WCB, RAL 5005 signal-blue epoxy-coating or compl. made of stainless steel CF-8M resp. SS316L
- Linings and encapsulations made of PFA or PFA-AS (conductive)
- Discs encapsulated or solid made of SS316L, Titanium Gr.2 or Hastelloy®C
- Easy installation into existing piping systems, for silent operation, maintenance-free
- Centering lugs
- Locked disc
- Face to face acc. to EN 558-1, range 20

CE Conformity acc. to European Pressure Equipment Directive 97/23/EC (PED)

Operating Conditions

- Temperature range from -40°C (-40°F) up to +200°C (+392°F), depending on lining material
- Pressure range from 1 mbar (0.01 psi) up to 10 bar (145 psi), depending on size/pressure/temperature

Testing / Marking

- Pressure- and tightness testing acc. to EN 12266-1, leakage rate A, resp. API 598.
- Marking of valves on body and name plate acc. to EN 19.
- Material- resp. test certificates acc. to EN 10204-3.1/2.2/2.1

Pressure-/Temperature Diagram

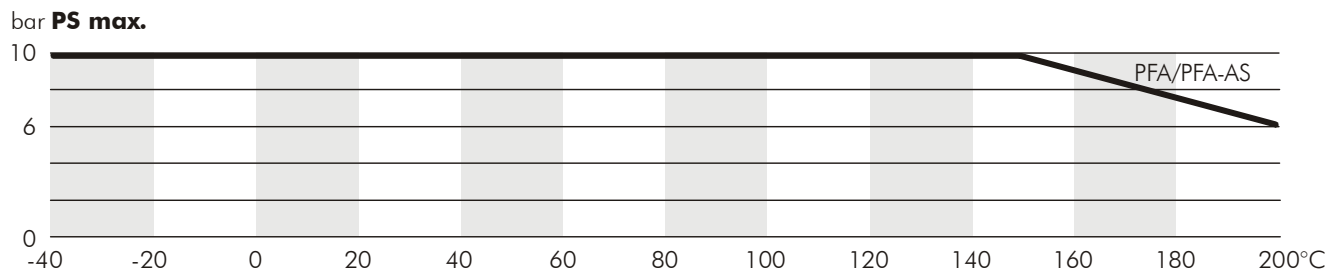

Standard Materials of Components

Body Cast steel 1.0619 (WCB) epoxy-coated
Disc core 1.4462 Duplex (C.Steel >DN300)
Lining/encaps. PFA acc. to ASTM D3307
Retainer Ring ¹⁾ Cast steel 1.0619 (WCB) epoxy-coated

Options

SS casting 1.4408 (CF-8M)
 Solid discs SS316L, Tit. Gr.2, Tit. Gr.7, Hast. C
 PFA-AS (conductive)
 1) 350/14" – 600/24" only

Technical Data

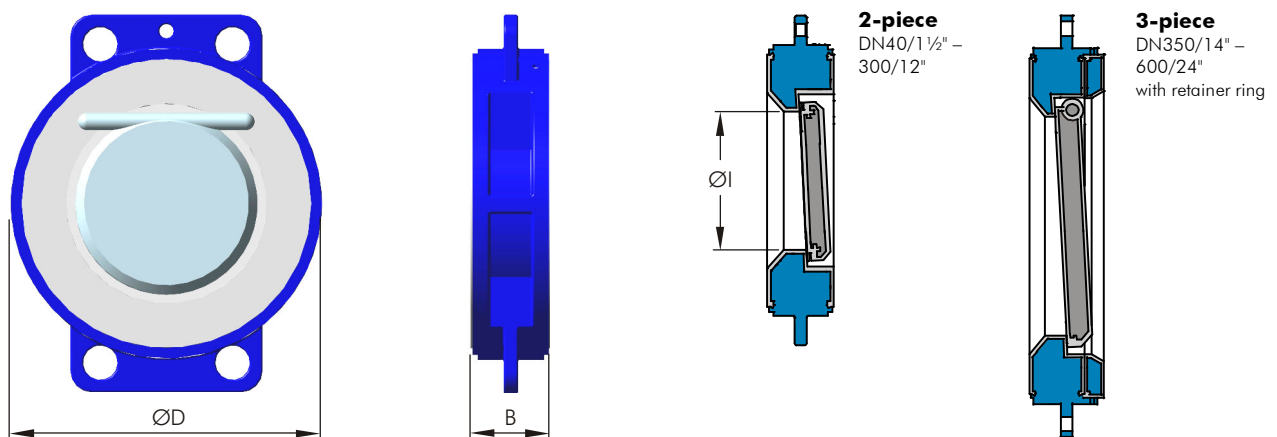

Dimensions in mm (lbs = kg x 2.2)

DN Size nom.	40 1 1/2"	50 2"	80 3"	100 4"	150 6"	200 8"	250 10"	300 12"	350 14"	400 16"	450 18"	500 20"	600 24"
ØD	82	101	133	160	217	268	325	375	437	487	537	592	694
Ø1	22	30	51	68	111	155	205	255	280	300	350	400	498
B	33	43	46	52	56	60	68	78	92	102	114	127	154
kg	1.1	2.1	3.6	5.8	9.0	14.5	21.0	31.5	55.0	76.0	115	152	216

Face to face acc. to DIN EN 558-1 range 20, appr. weights for DN450 – 600

other sizes or materials upon request

Specification

Project-/Customer Data		Inquiry/Date: _____		Ref. SF _____	
Company:		Contact Person:		Phone:	
Address:		Function:		Fax:	
ZIP/Place:		Department:		E-mail:	
Project:		Phone direct:		Mobile:	

Operating Conditions

Media / Chemical Composition:

<input type="checkbox"/> liquid	<input type="checkbox"/> powdery	<input type="checkbox"/> crystallizing	<input type="checkbox"/> sticky	<input type="checkbox"/> Spec. Grav. ____
<input type="checkbox"/> gaseous	<input type="checkbox"/> Solids ____ %	<input type="checkbox"/> viscous	<input type="checkbox"/> Flow Velocity ____ m/s	
<input type="checkbox"/> abrasive	<input type="checkbox"/> Particle ____ mm	<input type="checkbox"/> Visc. ____ cp	<input type="checkbox"/> Flow Rate ____ m ³ /hr	

Pressure

max. ____ bar
min. ____ bar

Temperature

max. ____ °C
min. ____ °C

Mode

On/Off
 Flow Control
____ cycles/ ____

Installation / Environment

horizontal Room dry
 vertical Room humid
 _____ outdoor

Remarks:

SSC Product Code

Specification of a complete Swing Check Valve SSC Series

Product code	Nom. size	Flange conn.	Body	Lining body	Disc	Options
SSC	DN100	PN16	G10	A85	U85	
	DN40 - 600 1 1/2" - 24"	PN16/150# PN10/150# ANSI300# JIS 10K	G10 WCB G15 CF-8M	A85 PFA A86 PFA-AS	U85 PFA U86 PFA-AS S32 SS316L S40 Tit. Gr.2 S41 Tit. Gr.7 S43 Hast. C-276	RAL... special paint